



UGB4-KLT with Sliding Handle



Gate Box with Safety Interlocking & RFID

UGB-KLT

Operating Instructions

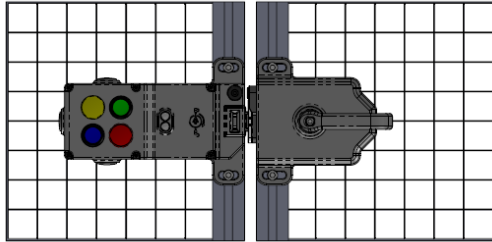

UGB4-KLT with Rotary Front Handle



UGB4-KLT

UGB2-KLT

Application:

The UGB-KLT Gate Box (incorporating an RFID interlock switch) is designed to fit to the leading edge of machine guard doors to provide robust guard locking and provide a double tamper resistant interlock mechanism. They are designed to provide position interlock detection for moving guards and will keep the guard locked until a voltage is applied to the switch solenoid. They will hold guards closed up to 3000N. They can be used in conjunction with delay timers to provide the solenoid energise signal only after a pre-determined time has run down. The UGB-KLT housings incorporate standard 22mm pushbuttons, switches or lamps to facilitate machine request functions and diagnostics all in one housing.

Operation:

The UGB-KLT is rigidly mounted to the fixed frame of the guard or machine. The actuator is fitted to the frame of the moving guard and is aligned to the switch entry aperture. The mechanical tongue actuator profile is designed to match a cam mechanism within the switch head and provides a positively operated not easily defeatable mechanical interlock. There is also an RFID coded actuator which aligns with a programmed receiver inside the switch housing during closing of the guard. Only when both actuators are in place and the RFID coding is verified correctly can the safety contacts close and allow the machine start circuit to be enabled. When the solenoid is energised the safety contacts are positively opened and the machine control circuit is broken. Optional features are Sliding Handles, Rotary Handles and a Rear Escape function.

Important:

Record any RFID codes as required by factory rules or with reference to any risk assessment for the particular application. The risk assessment for the particular application should include the risk of spare actuators. Spare actuators should not be readily available and must be securely controlled. The safety functions and mechanics must be tested regularly. For applications where infrequent guard access is foreseeable, the system must have a manual function test to detect a possible accumulation of faults. At least once per month for PLe Cat 3/4 or once per year for PLd Cat 3 (ISO13849-1). Where possible it is recommended that the control system of the machine demands and monitors these tests, and stop or prevents the machine from starting if the test is not done (see ISO14119). Ensure that the switch holding force (Fzh) is sufficient to withstand the static forces applied during normal use and dynamic effects caused by bouncing of the guard shall not create an impact reaction force which exceeds the holding force. If the expected impact reaction forces are higher than the specified holding force for the switch, then design measures must be applied to avoid the force. It is the responsibility of the user to ensure the correct overall functionality of its systems and machines. IDEM, its subsidiaries and affiliates, are not in a position to guarantee all of the characteristics of a given system or product not designed by IDEM.

Installation:

1. Installation of all IDEM interlock switches must be in accordance with a risk assessment for the individual application. Installation must only be carried out by competent personnel and in accordance with these instructions.
2. M5 mounting bolts must be used to fix the switch and actuator mounting. The tightening torque to ensure reliable fixing is 4.0 Nm. Tightening torque for the lid screws and cable glands must be 1.5 Nm to ensure the IP seal. Always fit the aperture plug to the unused entry aperture to prevent debris entering the switch mechanism.
3. If installing the UGB-KLT without using a Sliding or Rotary Handle then always fit a mechanical stop to the guard to prevent damage to the front of the switch. Always ensure correct alignment of actuator and handle with front apertures of the switch and guide. Use alignment guides to ensure that the actuator enters the switch without interfering with the sides of the aperture. Do not mount adjacent switches or actuators closer than 100mm. If fitted, the Manual override function is achieved by use of a tool and is to be used in exceptional circumstances. The release can be protected by use of a tamper coating to protect against unintended operation. If operated this tamper protection must be restored.
4. If fitting Sliding or Rotary Handles, ensure that M6 mounting bolts are used to fix the appropriate mounting plates. The tightening torque to ensure reliable fixing is 4.0 Nm.
5. The Front and Rear Rotary Handles can be adjusted for desired position by loosening the locking bolt which fixes the handle to the switch body.
6. The RFID code is factory set. For instances where replacement of the RFID actuator is required please contact IDEM via e-mail: technical@idemsafety.com
7. The Interlock Switch is supplied with removable conductor links fitted 41/42 and 31/32. If required by the control circuit these may be removed to offer independent monitoring of the solenoid locking function or the actuator position.
8. Always check the electrical ratings of any 22mm devices fitted. Never exceed these ratings.
9. After installation check operation of all control circuits, the locking function and rear escape functions. For applications with a run down time after removing power, ensure that the correct timing allowance has been made before the solenoid is energised.

Maintenance:

Every month: Check correct operation of all circuits and the Lock function. If any part of the UGB-KLT displays mechanical damage then remove and replace. IDEM will not accept responsibility for failure of the switch functions if the installation and maintenance requirements shown in this sheet are not implemented. Every 6 months: Isolate power and remove cover. Check screw terminal tightness and check for signs of moisture ingress. Re-check Installation conditions above. Never attempt to repair any switch. THESE INSTRUCTIONS FORM PART OF THE PRODUCT WARRANTY.



WARNING: DO NOT DEFEAT, TAMPER, OR BYPASS THE SAFETY FUNCTION. FAILURE TO DO SO CAN RESULT IN DEATH OR SERIOUS INJURY.

AVERTISSEMENT:

NE PAS DESACTIVER, MODIFIER, RETIRER, OU CONTOURNER CETI INTERVERROUILLAGE IL PEUT EN RESULTER DES BLESSURES GRAVES DU PERSONNEL UTILISATEUR

Original Instructions

To request this datasheet in other languages please contact info@idemsafety.com
Um dieses Datenblatt in Deutscher Sprache wenden Sie sich bitte anfordern info@idemsafety.com
Pour obtenir cette fiche en Francais, veuillez contacter info@idemsafety.com
Para solicitar esta hoja de datos en Espanol, por contacto con info@idemsafety.com

Gate Box with Safety Interlocking & RFID

LED DIAGNOSTICS (Interlock switch)

Switch State	LED 1 (Green/Yellow)	Comment
Guard Open	Off	
Guard Closed + Locked	Steady Green	Safety outputs ON
Guard Closed + Unlocked	Flashing Green	
Guard Closed + Misaligned / Wrong Actuator	Alternate Flashing Green/Yellow	
Fault	Steady Yellow	See 'RESET PROCEDURES' below

Solenoid State	LED 2 (Red)
Energised	ON
De-energised	OFF

RESET PROCEDURES - EITHER RESET PROCEDURE BELOW CAN BE USED TO RESET THE SWITCH (INTERNAL RESET BUTTON OR EXTERNAL RESET TERMINAL).

WARNING: AFTER COMPLETING THE RESET PROCEDURE NORMAL OPERATION OF THE SWITCH WILL RESUME, THIS INCLUDES ENABLING THE OUTPUTS IF INTERLOCKING AND LOCKING CONDITIONS ARE SATISFIED.



AVERTISSEMENT: APRÈS LE FAIT D'ACCOMPLIR LA PROCÉDURE L'OPÉRATION NORMALE DU CHANGEMENT REPRENDRA, CELA INCLUT LA PERMISSION DES PRODUCTIONS EN EMBOÛTANT ET EN FERMANT DES CONDITIONS SONT SATISFAITS.

If using INTERNAL RESET BUTTON (see Figure 1.)

In the event that a Fault condition requires reset, follow the reset instructions:

- 1) Turn off all power to the switch and open the guard.
- 2) Remove the switch cover.
- 3) Using a 2mm terminal screwdriver hold down the RESET button inside the switch housing and turn on the switch power (see Figure.1).
- 4) Release the RESET button, the yellow LED will flash, close the guard and the yellow LED will turn steady yellow.
(If yellow LED continues to flash check for mechanical fault (e.g. damaged actuator or switch head)).
- 5) Turn power off and then on, the green LED will illuminate and normal operation is resumed.
- 6) Re-fit the switch cover.
- 7) Open and close the guard ensuring all safety functions are correct –refer to any risk assessment for the particular guard application.

If using EXTERNAL RESET INPUT (Terminal 'ER')

- 1) Provide a 24V DC signal with a rising edge (0V to 24VDC) to the external reset input terminal ('ER').
- 2) Once the correct reset signal is detected at the 'ER' terminal the yellow LED will flash for 2 seconds before normal operation resumes.

RESET button

(If required press and hold using a 2mm terminal screw driver)

SPECIFICATION

Standards	IEC60947-5-3 ISO14119 ISO13849-1 IEC62061 UL508	
Supply Voltage	24Vdc (+/- 10%)	
Power Consumption	R+ 1.2W (50mA Max.) S+ 12W (500mA Max.)	
Safety Circuits	24Vdc 200mA max. switching.	
Auxiliary Circuits (34 & 44)	24Vdc 200mA max. Output feed.	
Rated Insulation Voltage	500VAC	
Rated Impulse withstand	1000VAC	
Holding Force	F1Max 3000N Fzh 2307N	
Classification and coding level (ISO14119)	Type 4 High	
Assured locking distance	5mm	
Sao (RFID)	10mm	
Sar (RFID)	20mm	
Max operating frequency	1Hz	
Actuator entry minimum radius	175mm	
Body Material	Stainless Steel 316 or Die-cast (painted red)	
Head Material	Stainless Steel 316	
Mechanical Actuator Material	Stainless Steel 316	
Enclosure Protection	Die-Cast IP67 Stainless Steel 316 IP67 / IP69K	
Operating Temperature	-25°C to +40°C	
Mechanical Life Expectancy (B10d)	2.5 x 10 ⁶ cycles at 100mA load	
Vibration	IEC68-2-6, 10-55Hz+1Hz Excursion: 0.35mm, 1 octave/min	

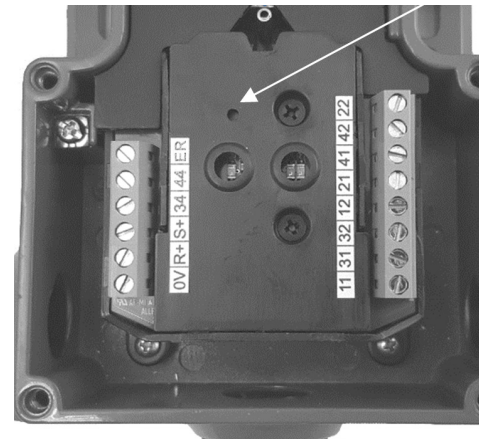

Figure 1. Switch cover removed.

Characteristic data according to IEC62021 (used as a subsystem)

Safety Integrity Level	SIL 3	
PFH (1/h)	4.77E-10	Corresponds to 4.8% of SIL3
PF	4.18E-05	Corresponds to 4.2% of SIL3
Proof Test Interval T ₁	20a	

Characteristic data according to EN ISO13849-1

Performance Level	e	If both channels are used in conjunction with a SIL 3 / PL e control device.
Diagnostic Coverage DC	99% (High)	
Category	Cat 4.	
MTTF _d	1100a	

Number of operating days per year: d_{op} = 365d
Number of operating hours per day: h_{op} = 24h

When the product is usage differs from these assumptions (different load, operating frequency, etc.) the values have to be adjusted accordingly

Information with regard to UL 508: Type 1 enclosure.
Maximum temperature 40°C.
Use 16-28AWG copper conductors (rated 90°C). Terminal Torque 6 lb ins. (0.7Nm).
Intended for same polarity use.
Safety Circuits (11-31 & 21-41) A300 Pilot Duty. 240V. 3A.
(PF 0.38 or greater tested for 6,000 cycles endurance).
Use one polymeric conduit connection. Not suitable for connection to rigid metal conduit.
(Earth bonding terminal inside enclosure if required – use 16-12AWG conductors).
Push Button ratings (Optional) 120 -240 Vac, 1.5 - 1.0 A 24 - 125 Vdc, 0.3 – 0.2 A

Interlock Schematic - (internal wire links not removed).

Note: Circuits 21/41 and 11/31 are lock monitoring contacts. (Closed when switch is locked).
Circuits 42/22 and 32/12 are interlock monitoring circuits. (Closed when guard is closed).

Interlock Switch Circuit – Terminal connections.

(Use 16-28AWG copper conductors. Terminal Torque 6 lb ins. (0.7Nm)).

0V	Supply 0V dc
R+ 24V dc	Supply 24V dc
S+ 24V dc	Unlock signal (solenoid) apply +24V dc
11/12	Safety interlock and lock monitoring circuit (link wire fitted)
21/22	Safety interlock and lock monitoring circuit (link wire fitted)
44	Guard open signal +24V dc out
34	Unlocked signal +24V dc out
ER	External Reset Signal (see 'RESET PROCEDURES')

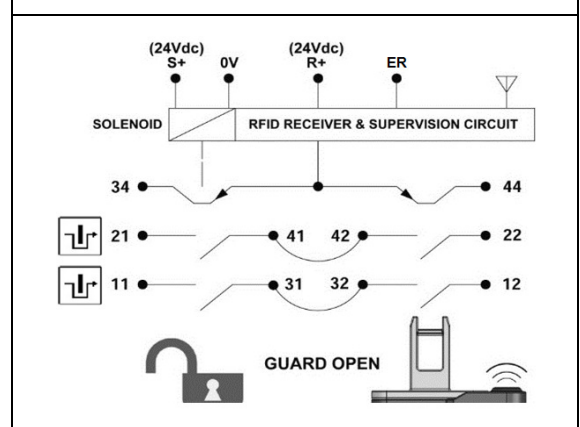

Gate Box with Safety Interlocking & RFID

Application Example: 4 STATION (UGB4) with Front Rotary Handle, Rear Escape Button and Rear Escape Rotary Handle

Viewed from OUTSIDE GUARDED AREA

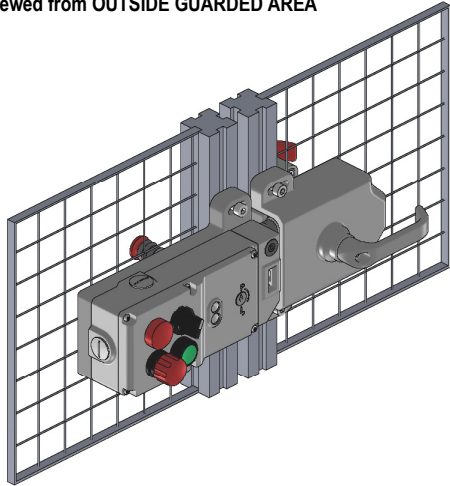

Viewed from INSIDE GUARDED AREA

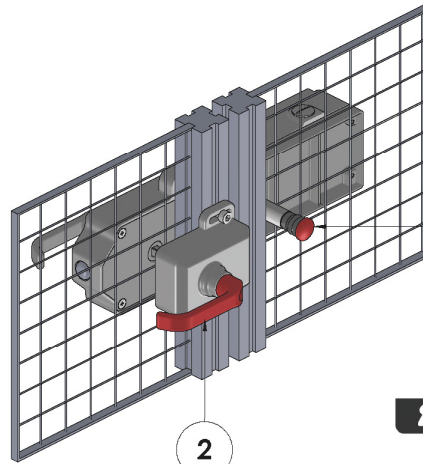

1 PRESS AND HOLD REAR RELEASE BUTTON



TO OPEN USING REAR HANDLE

2

TURN REAR HANDLE ANTI-CLOCKWISE

Specification:

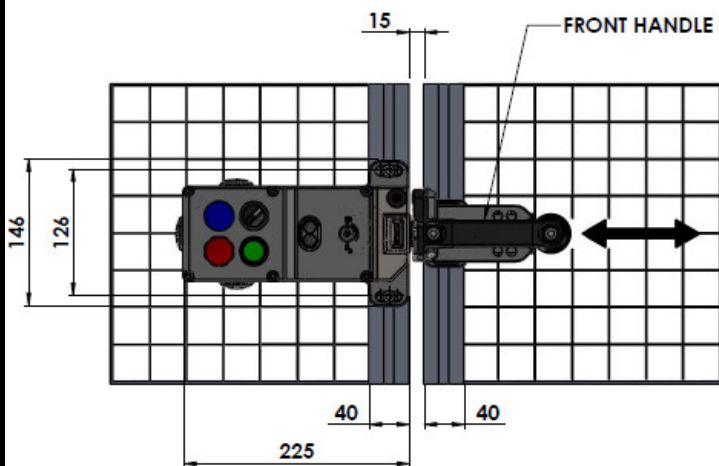

FRONT HANDLE

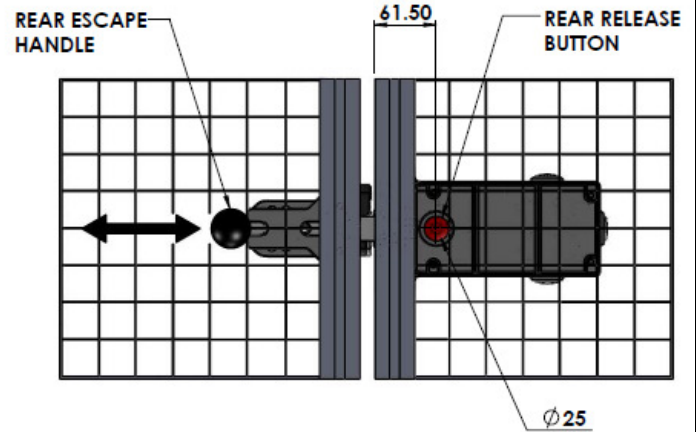

REAR ESCAPE HANDLE

REAR RELEASE BUTTON

$\phi 25$

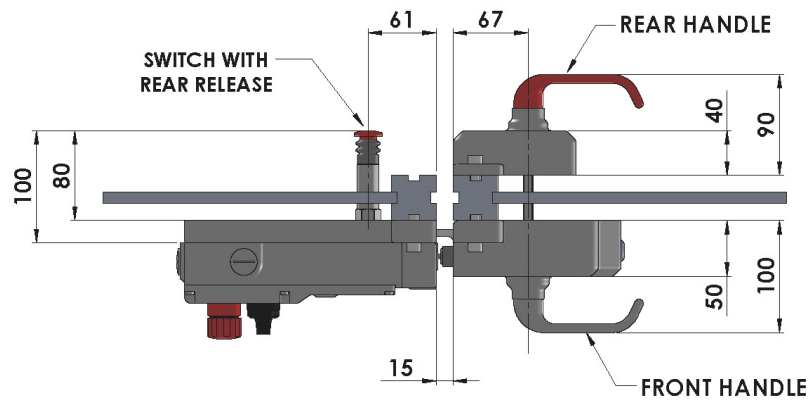

SWITCH WITH REAR RELEASE

REAR HANDLE

FRONT HANDLE

Gate Box with Safety Interlocking & RFID

Application Example: 2 STATION (UGB2) with Front Rotary Handle, Rear Escape Button and Rear Escape Rotary Handle

Viewed from OUTSIDE GUARDED AREA

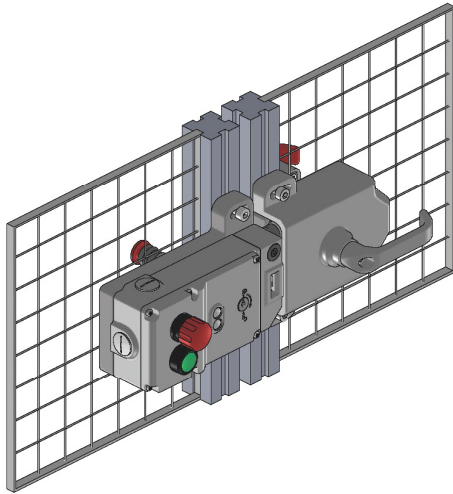

Viewed from INSIDE GUARDED AREA

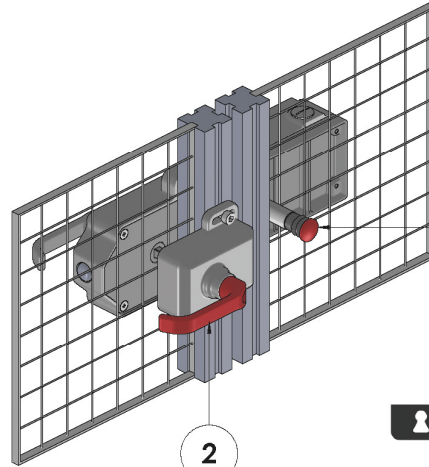

1 PRESS AND HOLD REAR RELEASE BUTTON



TO OPEN USING REAR HANDLE

2

TURN REAR HANDLE ANTI-CLOCKWISE

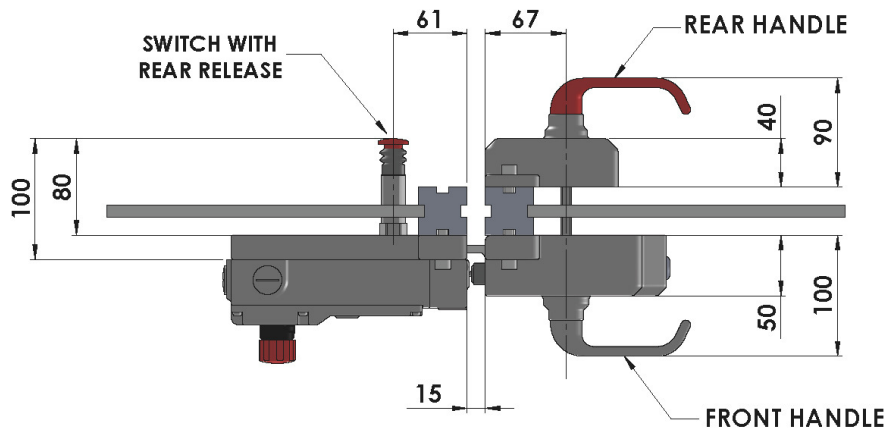
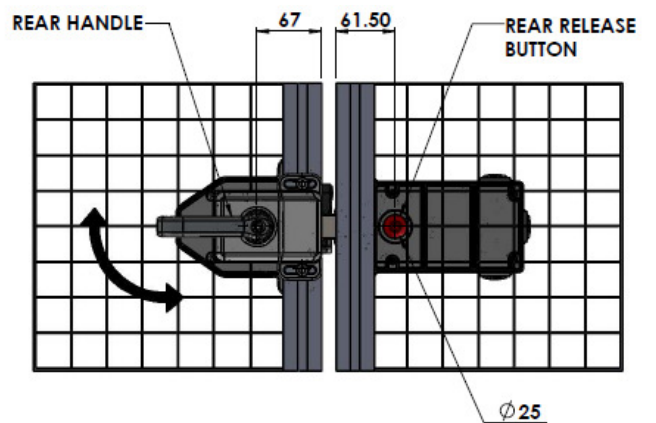
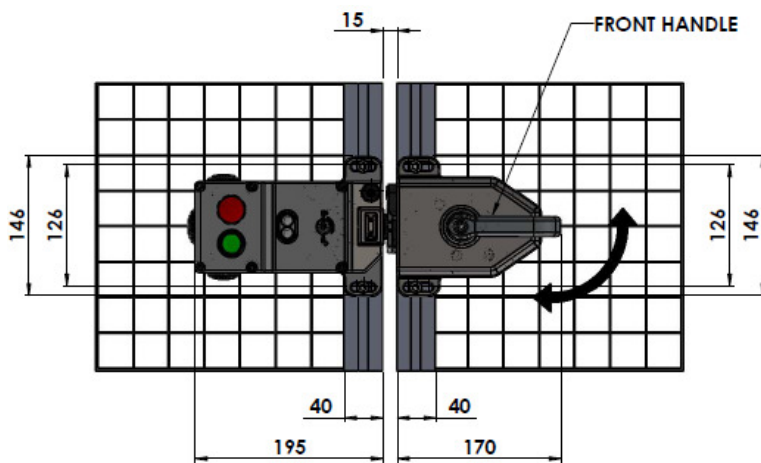

Gate Box with Safety Interlocking & RFID

Product Dimensions – Type: UGB 4-KLT-SS-RFID

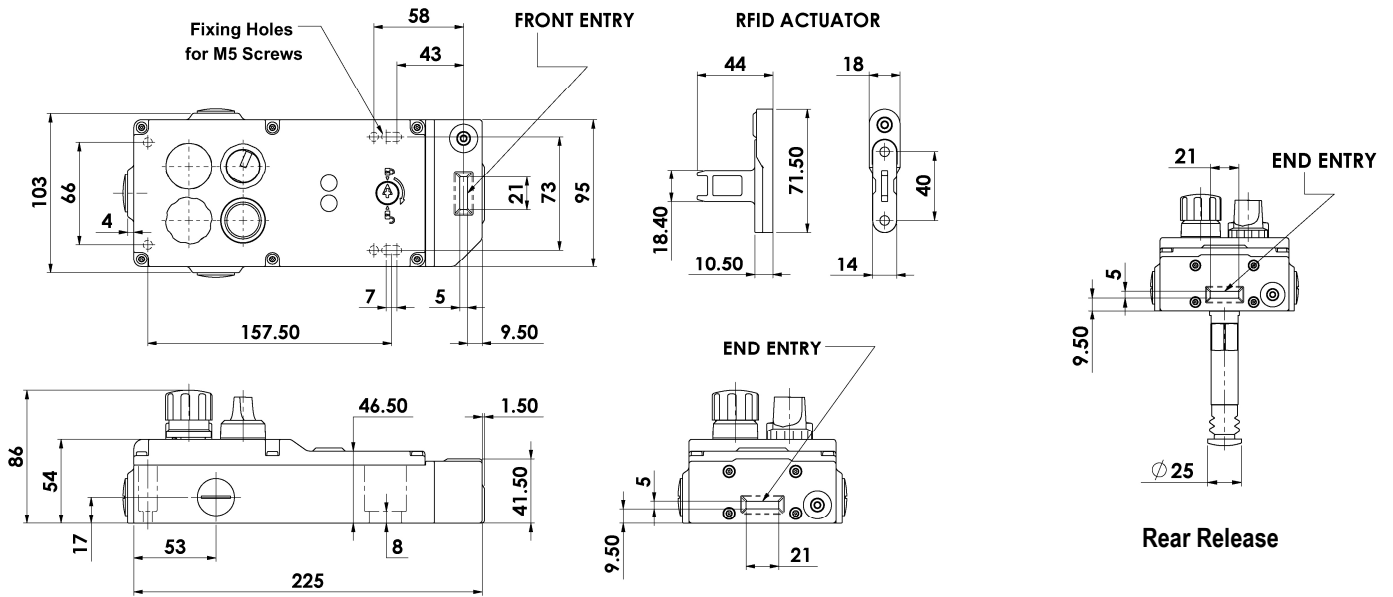

Product Dimensions – Type: UGB 4 Rotary Handle SS (4 x APP)

Product Dimensions – Type: UGB Rotary Rear Handle

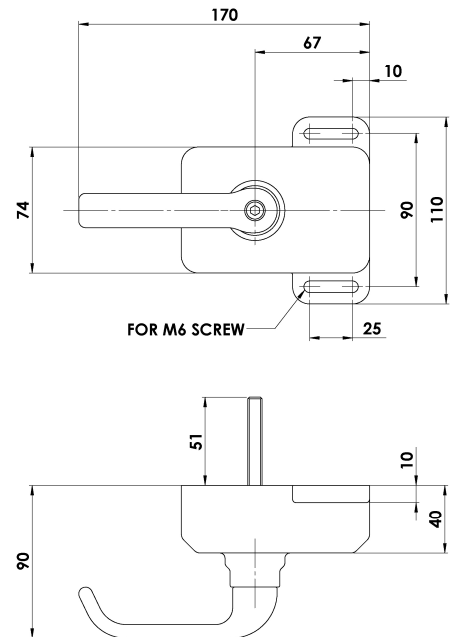
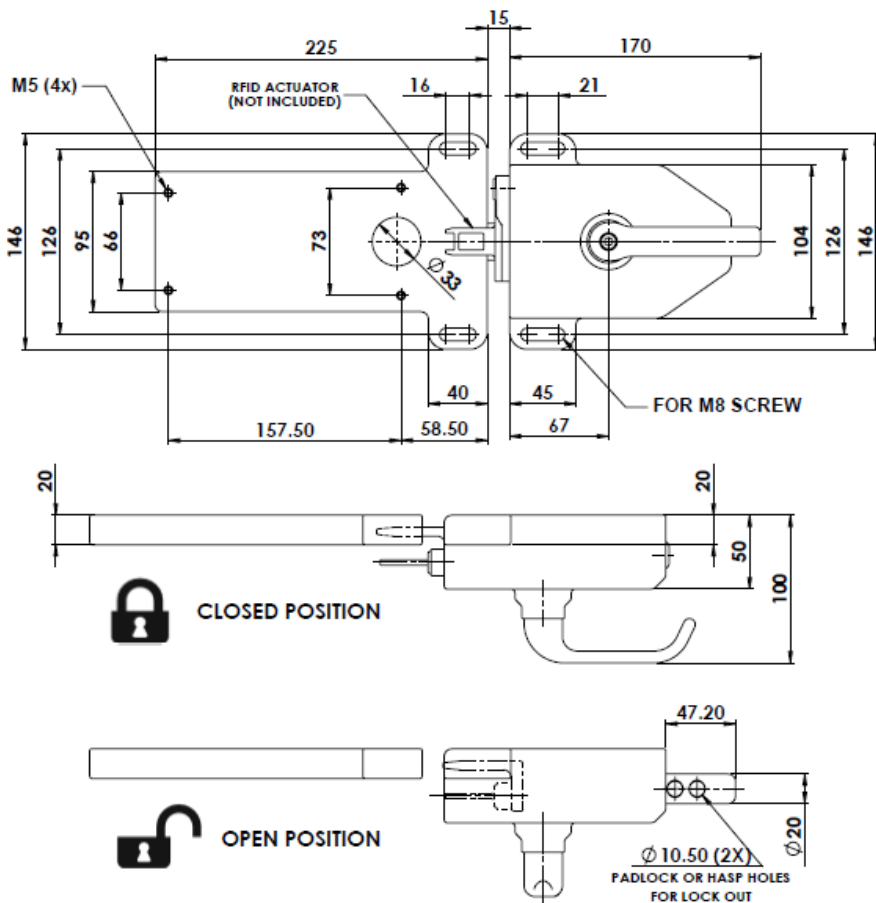

Gate Box with Safety Interlocking & RFID

Product Dimensions – Type: UGB 4 Sliding Handle SS (4 x APP)

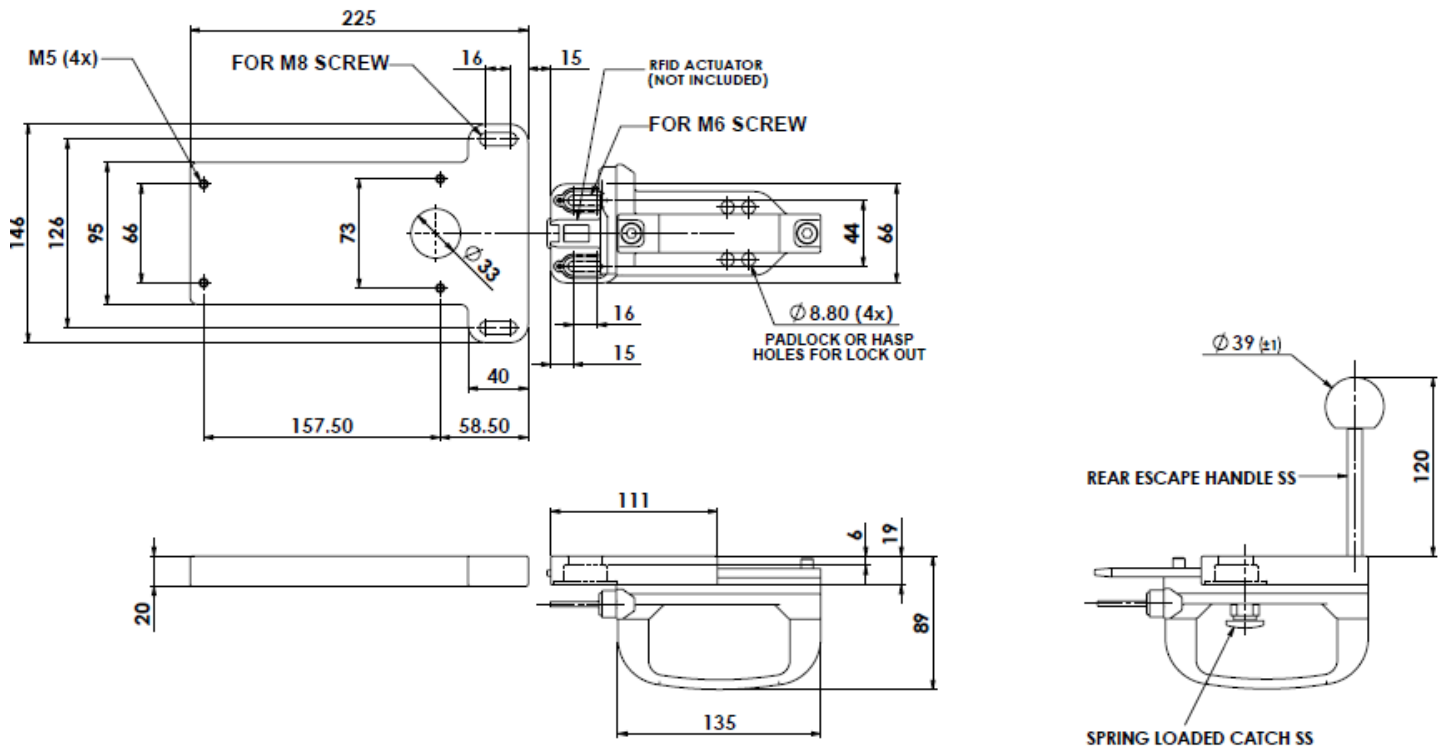

Product Dimensions – Type: UGB 2-KLT-SS-RFID

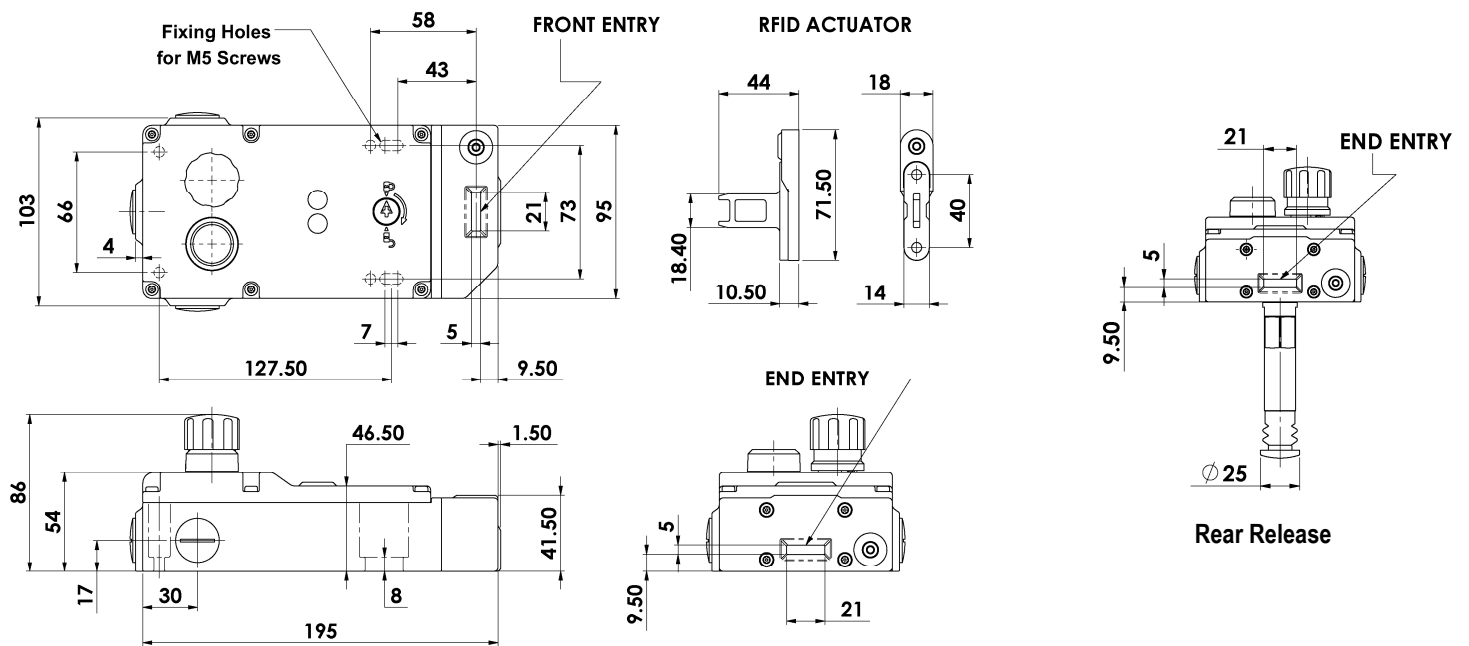

Gate Box with Safety Interlocking & RFID

Product Dimensions – Type: UGB 2 Rotary Handle SS (2 x APP)

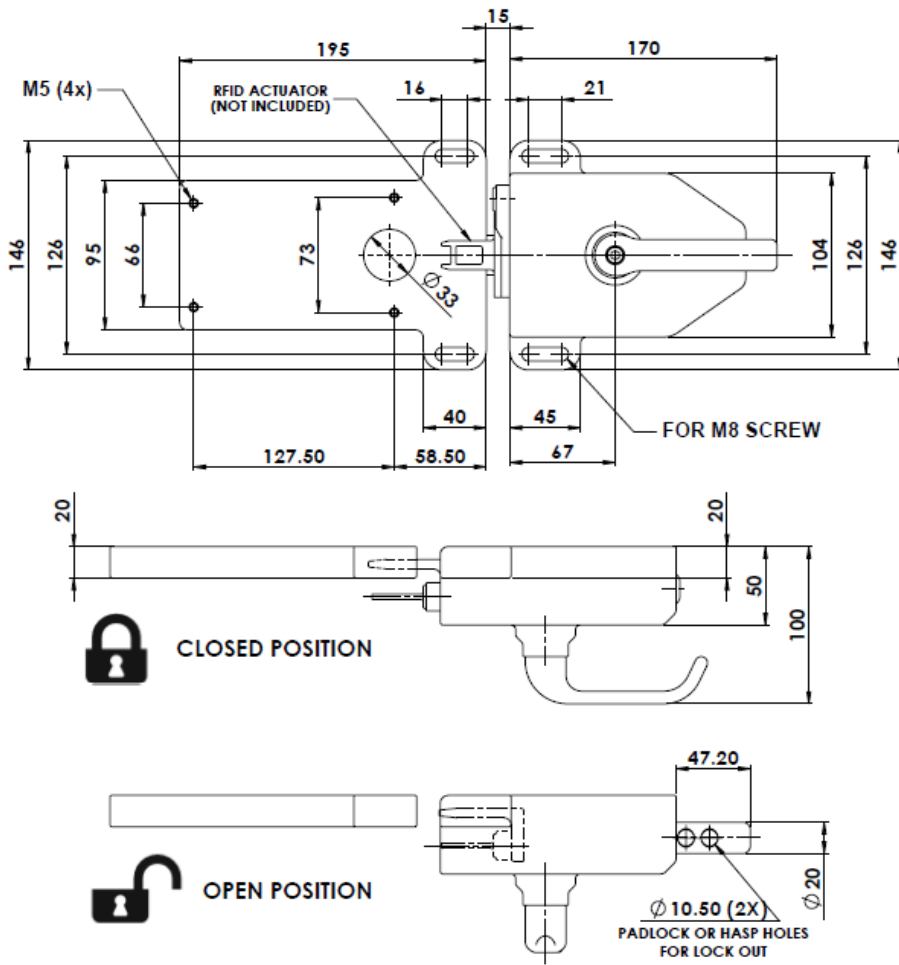

Product Dimensions – Type: UGB Rotary Rear Handle

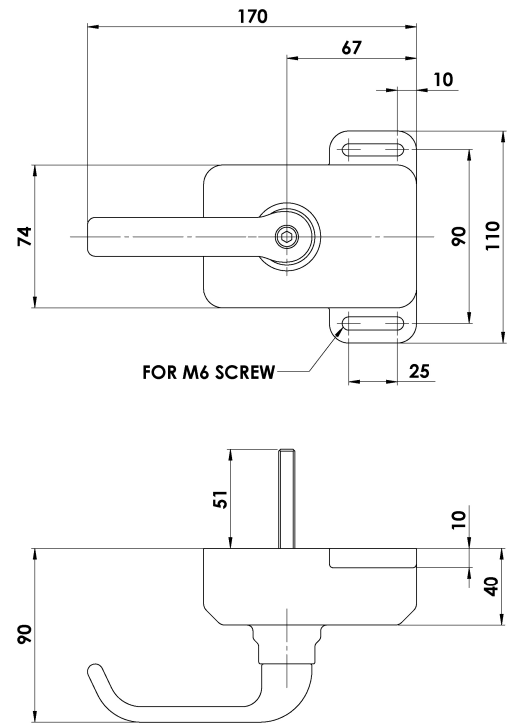

Product Dimensions – Type: UGB 2 Sliding Handle SS (2 x APP)

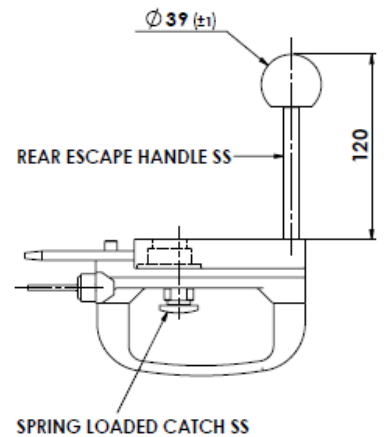
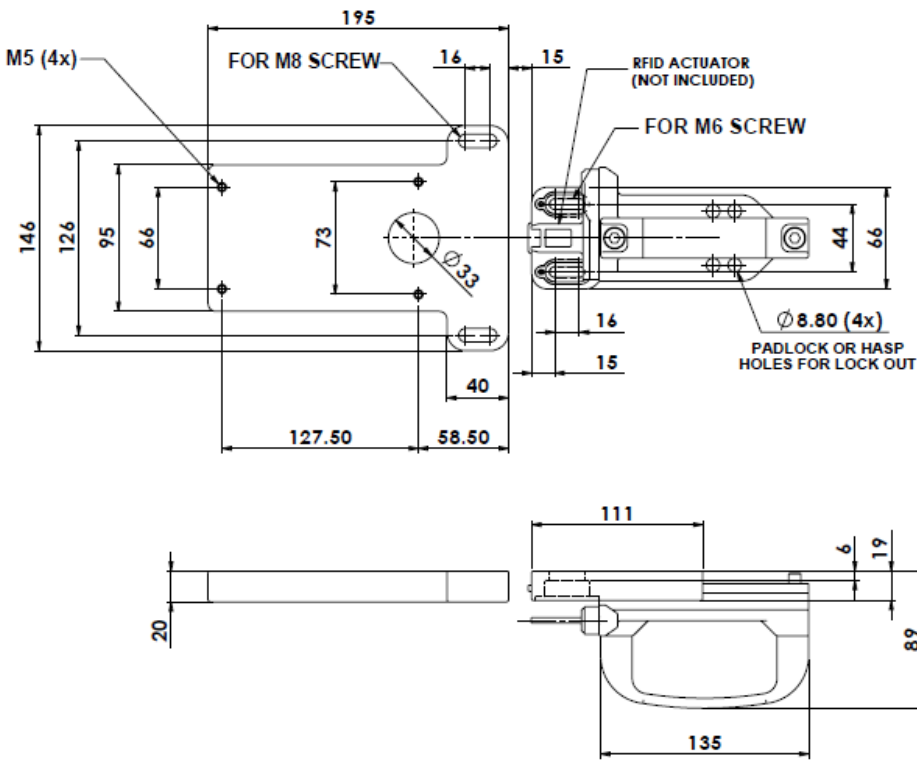

Gate Box with Safety Interlocking & RFID